



GH3 Twin Lifting module Technical specifications

Weight and materials

SWL	: 250 kg, 375 kg, 500 kg
Own weight	: 19,2 kg

Covers : Impact-resistant UL 94 V-0 flame retardant recyclable plastic

Dimensions

A	: 860 mm
B	: 817 mm
C	: 156 mm
D	: 184 mm
E, min	: 655 mm
F, max	: 3155 mm
G	: 473 mm
Depth of hoist	: 205 mm

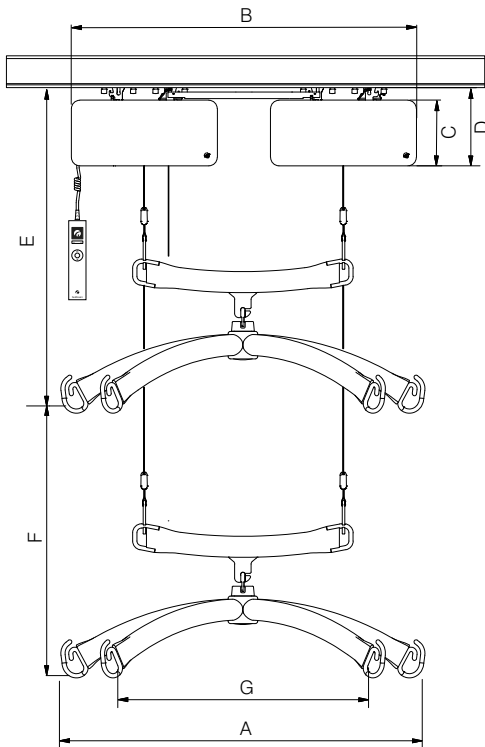

Functions

Operation	: Hand control / IR
Sound level	: 52 dB (A)

Safety

Emergency stop	: Yes
Emergency lowering device	: Yes, mechanical and electrical
Control of lifting strap	: Yes
Cut-off angle	: 45° along the rail 10° across the rail

Electronics

On/off	: Automatic when used. Soft start/stop. Overload protection.
Battery	: 24 V NiMH, 2 x 2.1 Ah
Max charge time	: 4 hours
Battery protection	: At battery voltage below 22 V the indicator light turns orange. The hoist is stopped if the voltage falls below 20 V
Power supply	: 33 V AC, 2.5 A
Supply voltage, transformer Class I	: 100-240V AC
transformer Class II	: 100-115V AC / 220-230V AC

Protection classification (IP) according to IEC 60529

Lifting module	: IP 20
Hand control	: IP 44
Remote control	: IP 20
Transformer Class I	: IP 20
Transformer Class II	: IP 21

Labelling

The product is manufactured in compliance with regulation (EU) 2017/745 of the European parliament and of the Council of 5 April 2017, as medical device Class I.

Classification

Pursuant to ISO 9999

Patents

: PA 2008 00888
: PA 2008 00894
: PA 2008 00895

Time to care



GH3 Twin Lifting module Technical specifications

GH Lifting modules, configurations			Options													
Guldmann hoist type	Lifting speed, mm/s (Normal / Turbo)	Load in kg	Wi-Fi enabled	Data transmission shown on MyGuldmann	Hand control with display	Function on demand	Scale	Class III scale	Trainer	Coating	UL	Automatic charging	Charging in docking station	Positioning lock	IR remote ^{x)}	Horizontal drive motors ^{x)}
GH3+ Twin	60/100	250	✓	✓	✓	•	•	•		•	•	✓				
		375	✓	✓	✓	•	•			•	•	✓				
		500	✓	✓	✓	•	•	•		•	•	✓				

- *Optional*
- ✓ *Always included*
- x) *Not compatible with UL*

GH3 Twin	
Lifting speed	
85 kg load	60 mm/sec.
150 kg load	60 mm/sec.
Max capacity load, SWL	55 mm/sec.
Max 5 kg load	60/100 mm/sec.

Number of lifts and Intermittent

Max. number of lifts in series : 55 with 85 kg/1000 mm
 Charging time : 4 hours
 Intermittent : 2 min. ON/18 min. OFF

Max. number of lifts in series : 21 with 250 kg/1000 mm
 Charging time : 4 hours
 Intermittent : 2 min. ON/18 min. OFF

Max. number of lifts in series : 21 with 375 kg/1000 mm
 Charging time : 4 hours
 Intermittent : 2 min. ON/18 min. OFF

Max. number of lifts in series : 21 with 500 kg/1000 mm
 Charging time : 4 hours
 Intermittent : 2 min. ON/18 min. OFF